

Comment les jumeaux numériques permettent-ils d'intégrer efficacement les énergies renouvelables aux réseaux autonomes?

En collaboration avec



OPAL-RT
TECHNOLOGIES

Ege Dundar
18 juin 2020



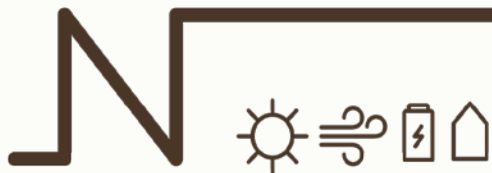

Secteurs d'activité

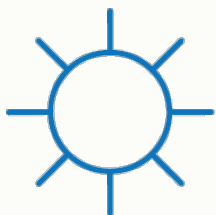

Énergie solaire photovoltaïque
« Une énergie qui rayonne »

Énergie éolienne
« Un vent d'énergie »



Intégration des énergies
renouvelables
« Redéfinir l'approvisionnement
énergétique »



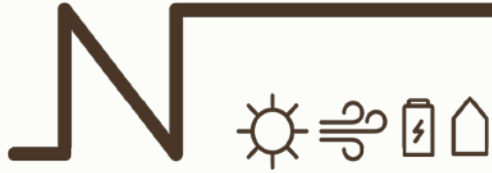

Plan

- Définition du jumeau numérique et utilisations actuelles
- Jumeau numérique et intégration des énergies renouvelables dans les microréseaux
- Résultats préliminaires
- Conclusions et perspectives
- Période de questions





Selon vous, qu'est-ce qu'un jumeau numérique?



Un dessin technique assisté par ordinateur



La représentation virtuelle d'un objet



Un modèle numérique



Toutes ces réponses



Définition du jumeau numérique (JN)

Pas de définition standard

« Le concept de JN [...] comprend trois éléments principaux : **a) les produits physiques** dans l'espace réel; **b) les produits virtuels** dans l'espace virtuel; et **c) les connexions de données et d'informations** qui relient les produits virtuels et réels. »

- M. Grieves

« Au sens large, un JN est un **système intégré** qui peut **simuler, surveiller, calculer, réguler et contrôler** l'état et le processus du système. »

- Zheng et al.

« [... Un] JN complet devrait comprendre cinq éléments : **partie physique, partie virtuelle, connexion, données et services.** »

- Qi et al.



Définition simplifiée

Le JN est une représentation virtuelle d'une entité physique



Source : <https://www.ptc.com/en/product-lifecycle-report/digital-twin-industry-4-0>



Chez Nergica, on considère qu'il y a 3 éléments au JN

1 - Produit physique

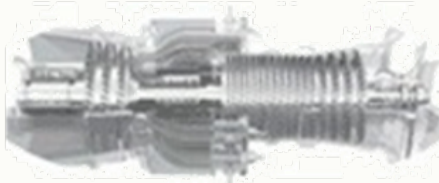

2 - Produit virtuel



3 - Connexion

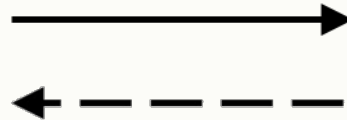



Des exemples d'applications



Villes intelligentes



Santé



Formule 1



Pourquoi maintenant?

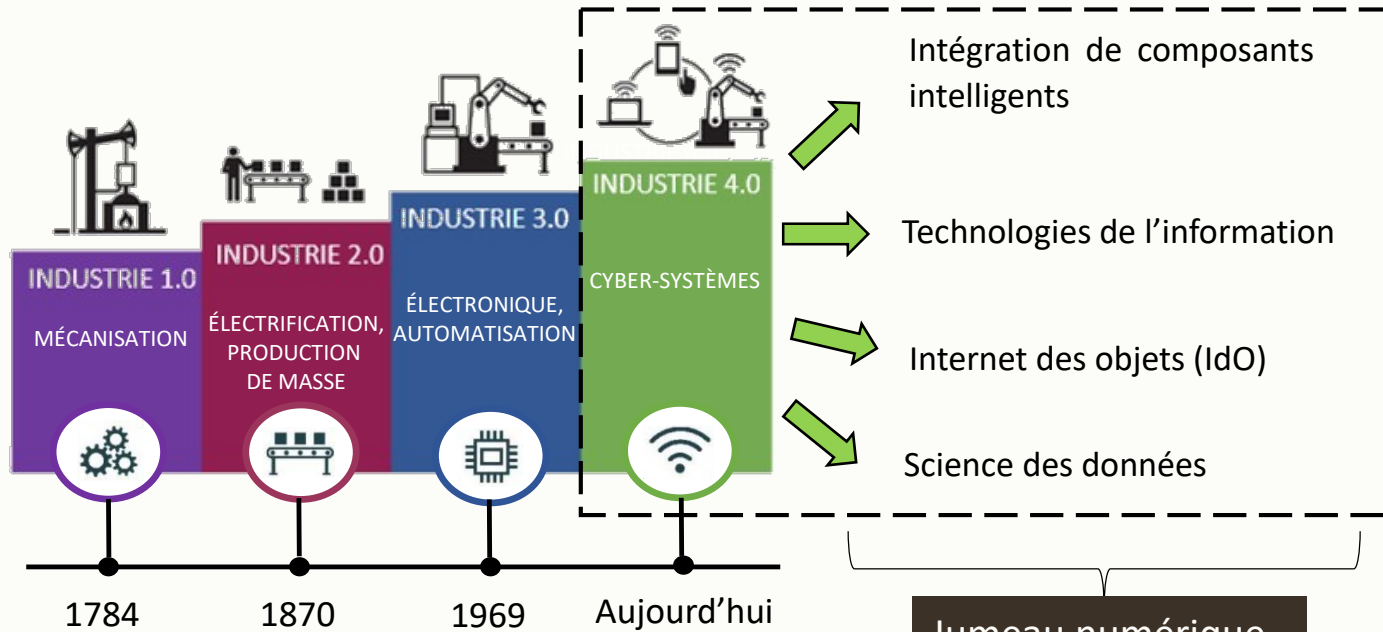

Jumeau numérique



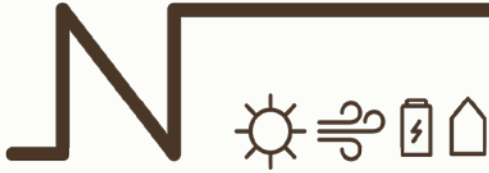

Dans quelles industries est-ce appliqué?

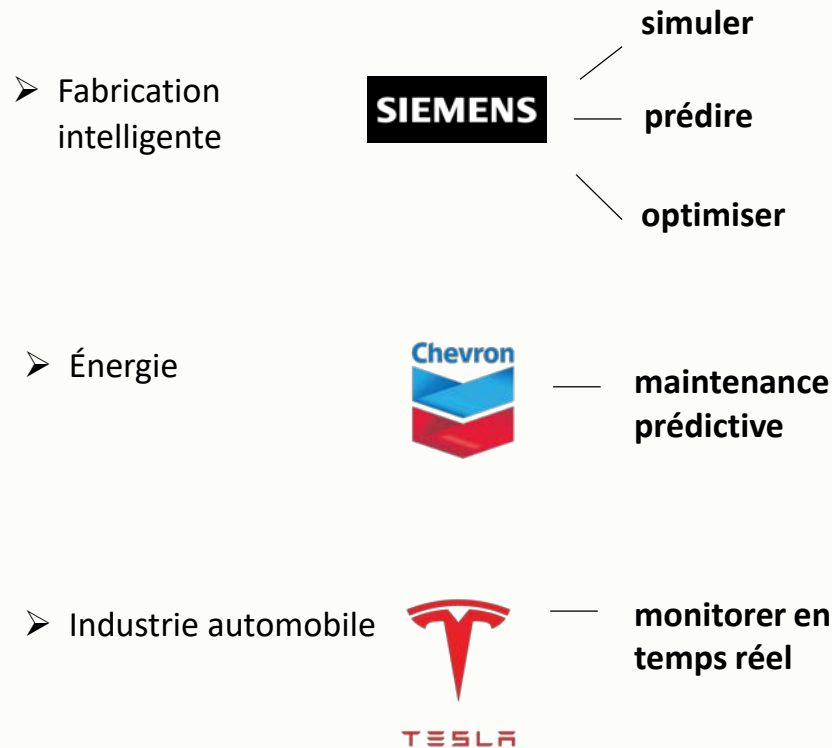



Dans quelles industries est-ce appliqué?

- Énergies renouvelables (parcs éoliens)



— **tester
différents
scénarios**

- Énergies renouvelables (parcs éoliens)



— **monitorer
en temps réel**





JN et intégration des énergies renouvelables dans les microréseaux

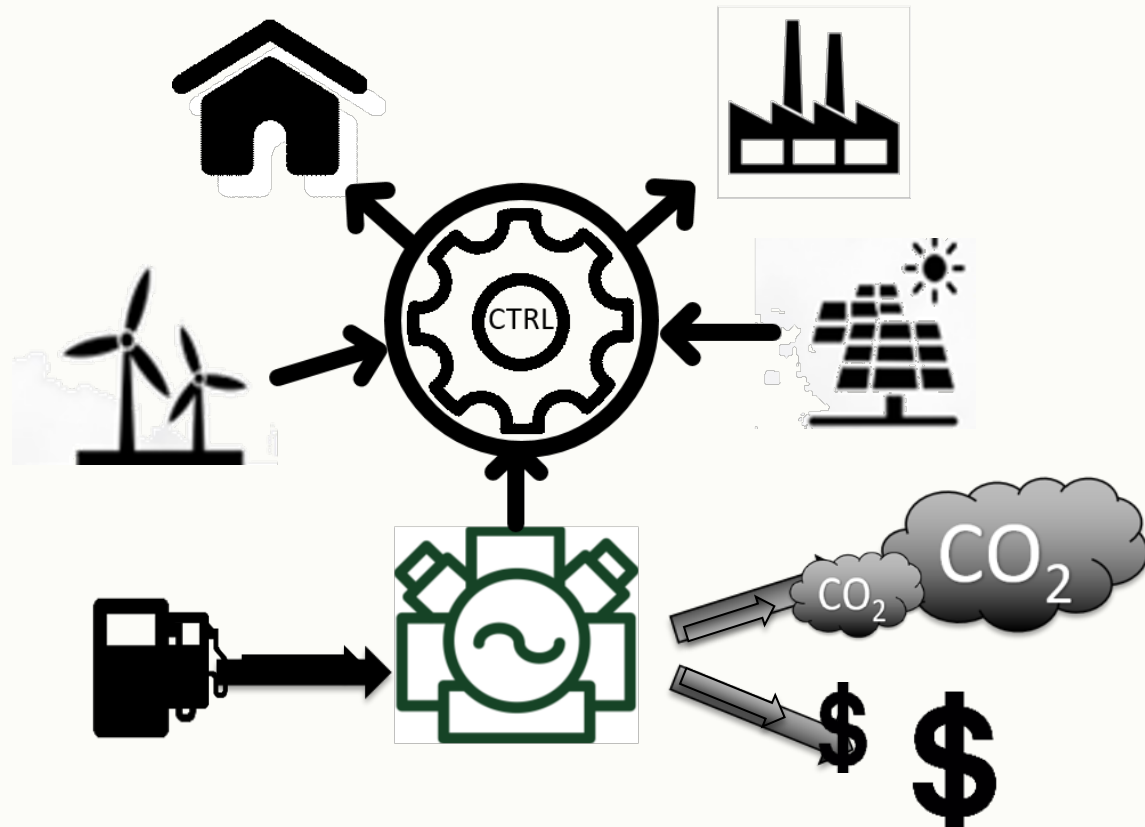



Le défi de l'intermittence

Systeme photovoltaïque

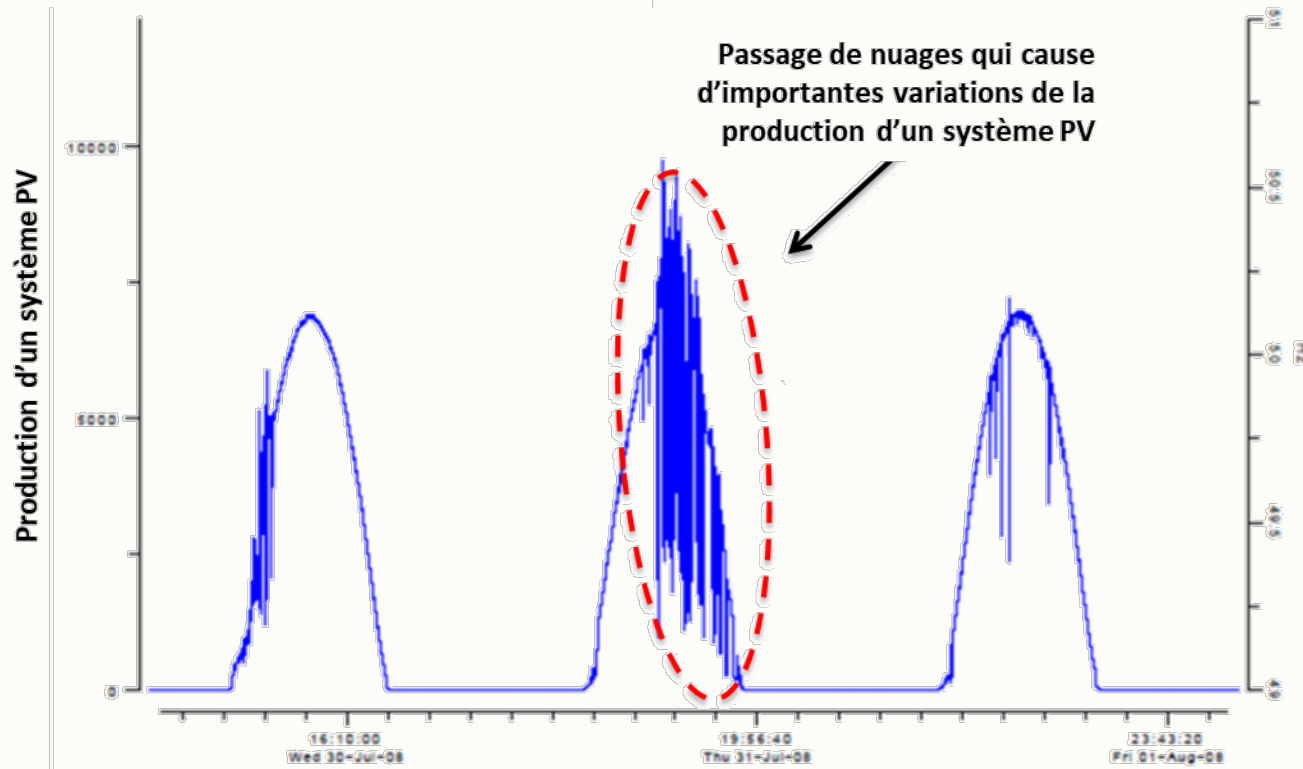

© TechnoCentre éolien, 2017



Le défi de l'intermittence

Systeme éolien

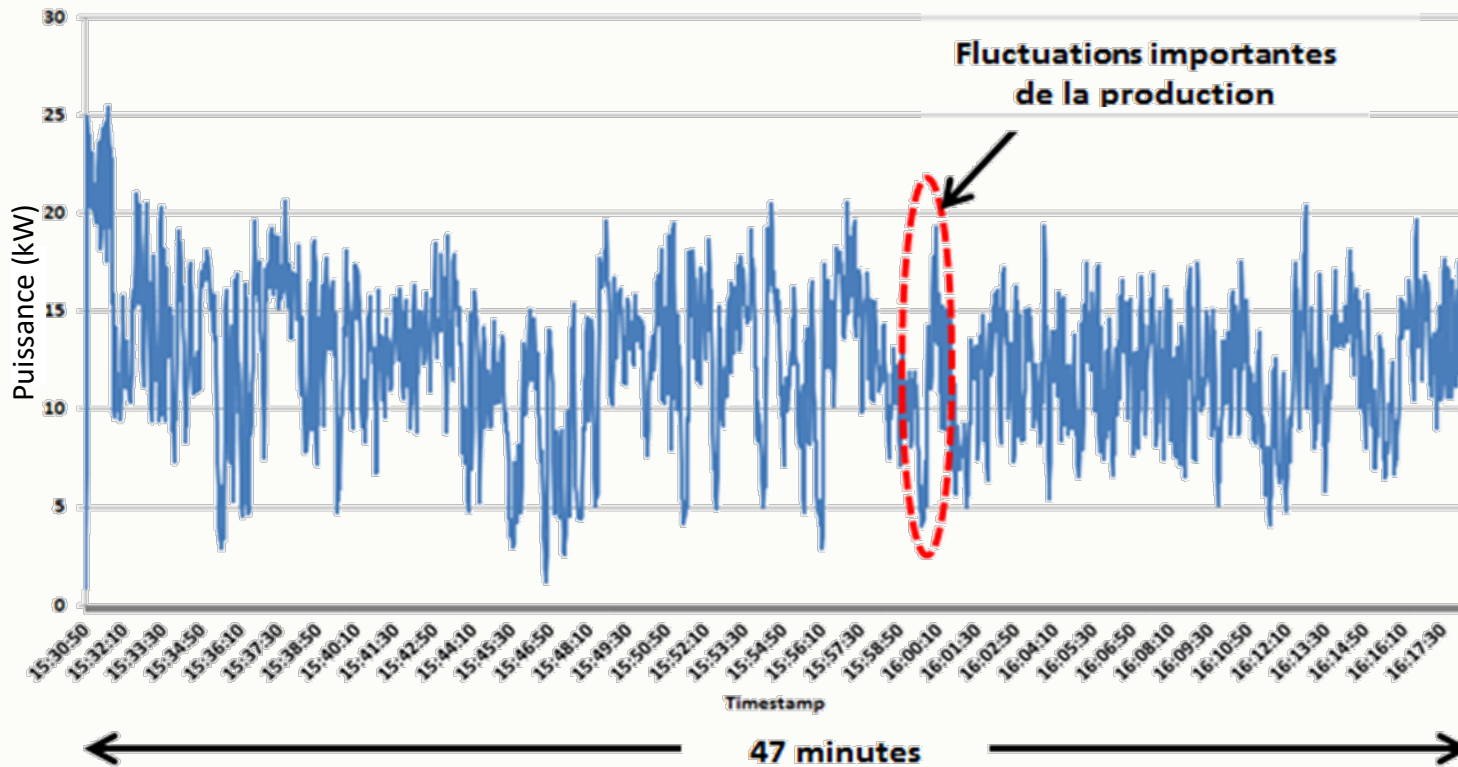



En quoi le JN peut-il aider à résoudre les problèmes liés à l'intégration des EnR?

- **Augmentation du taux de pénétration**
- **Développement de contrôleurs de microréseaux**
- **Amélioration des performances (maintenance prédictive)**





Initiative de Nergica

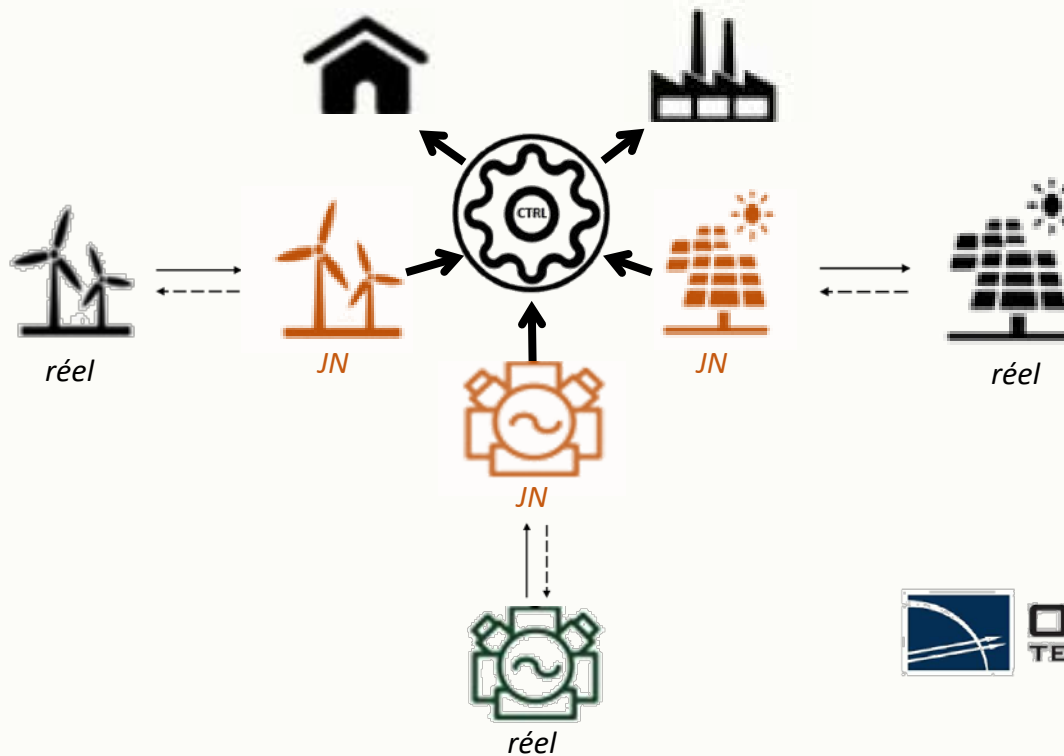

Objectif : améliorer le taux d'intégration des énergies renouvelables

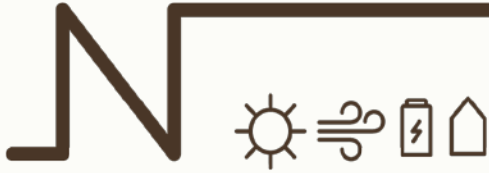

Éléments du JN | Système solaire PV de Nergica

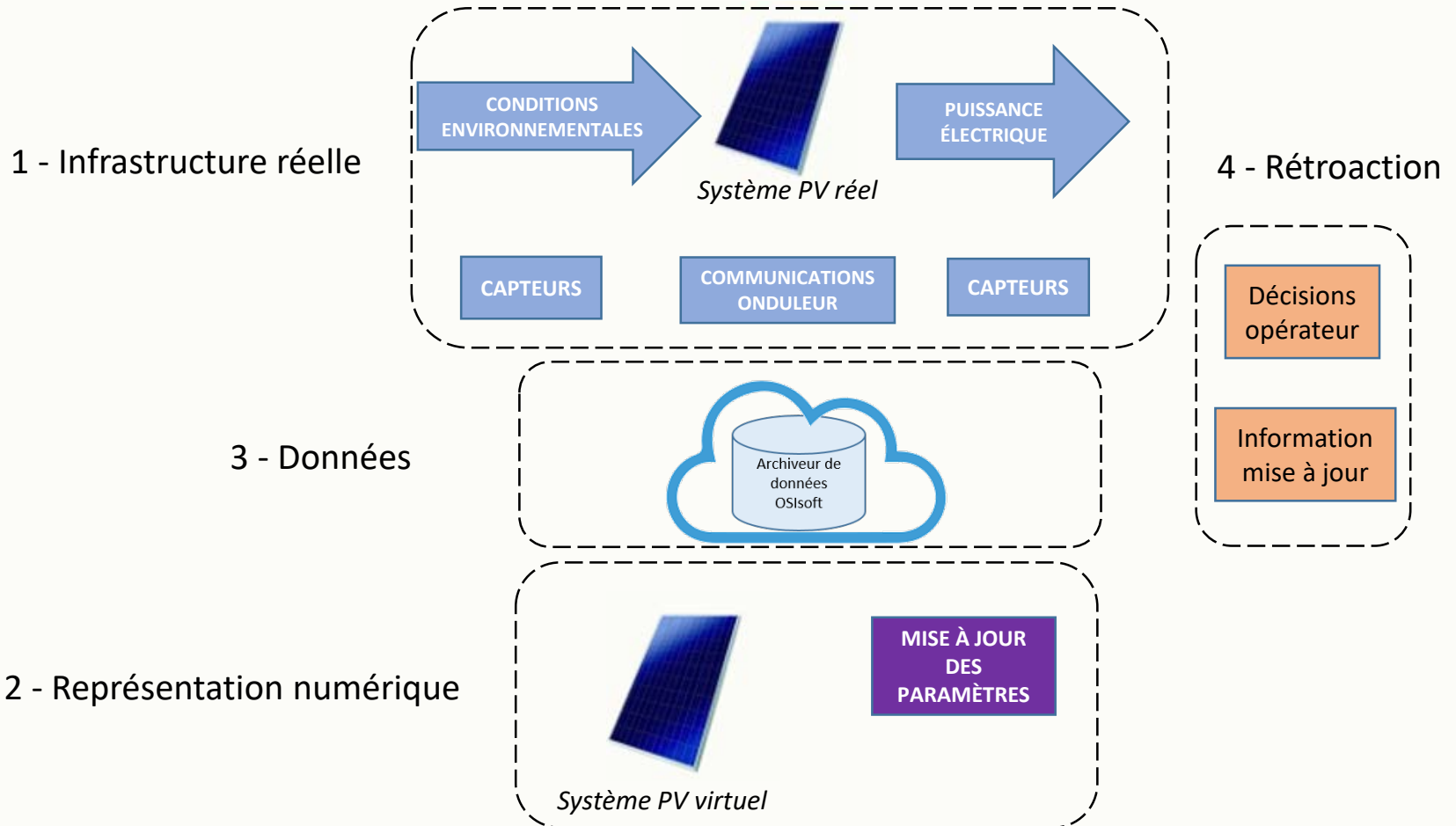

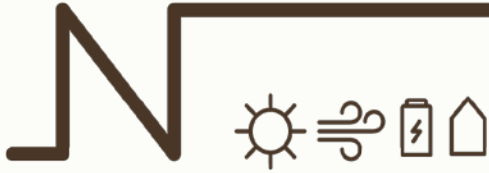

Communication

Échange de données en temps réel entre le simulateur et l'infrastructure physique

Site de recherche

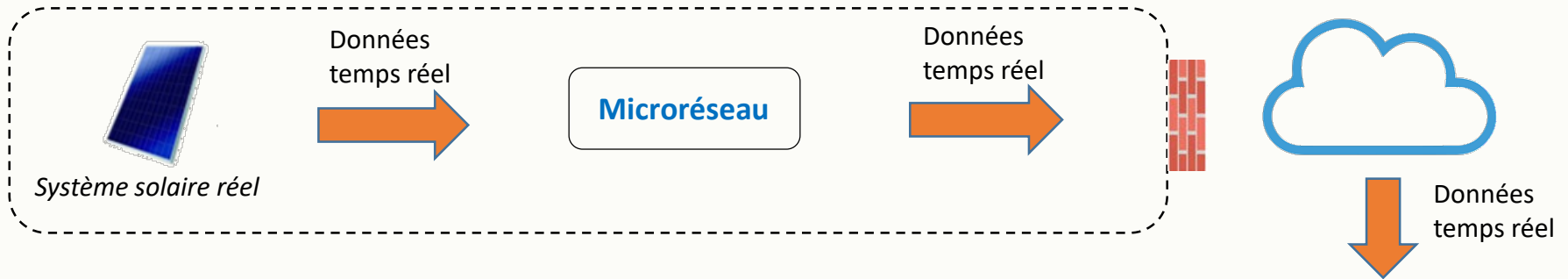

Gaspé

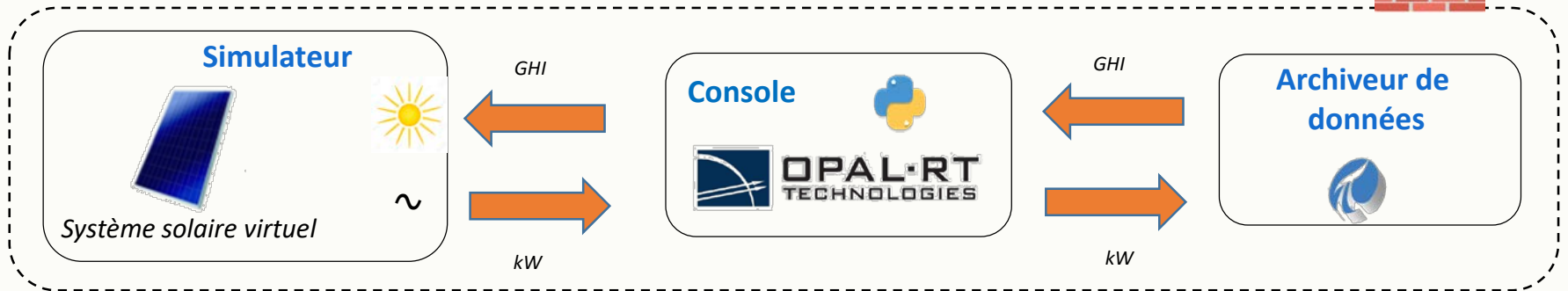



Résultats préliminaires

Jumeau numérique PV - Modèle numérique détaillé

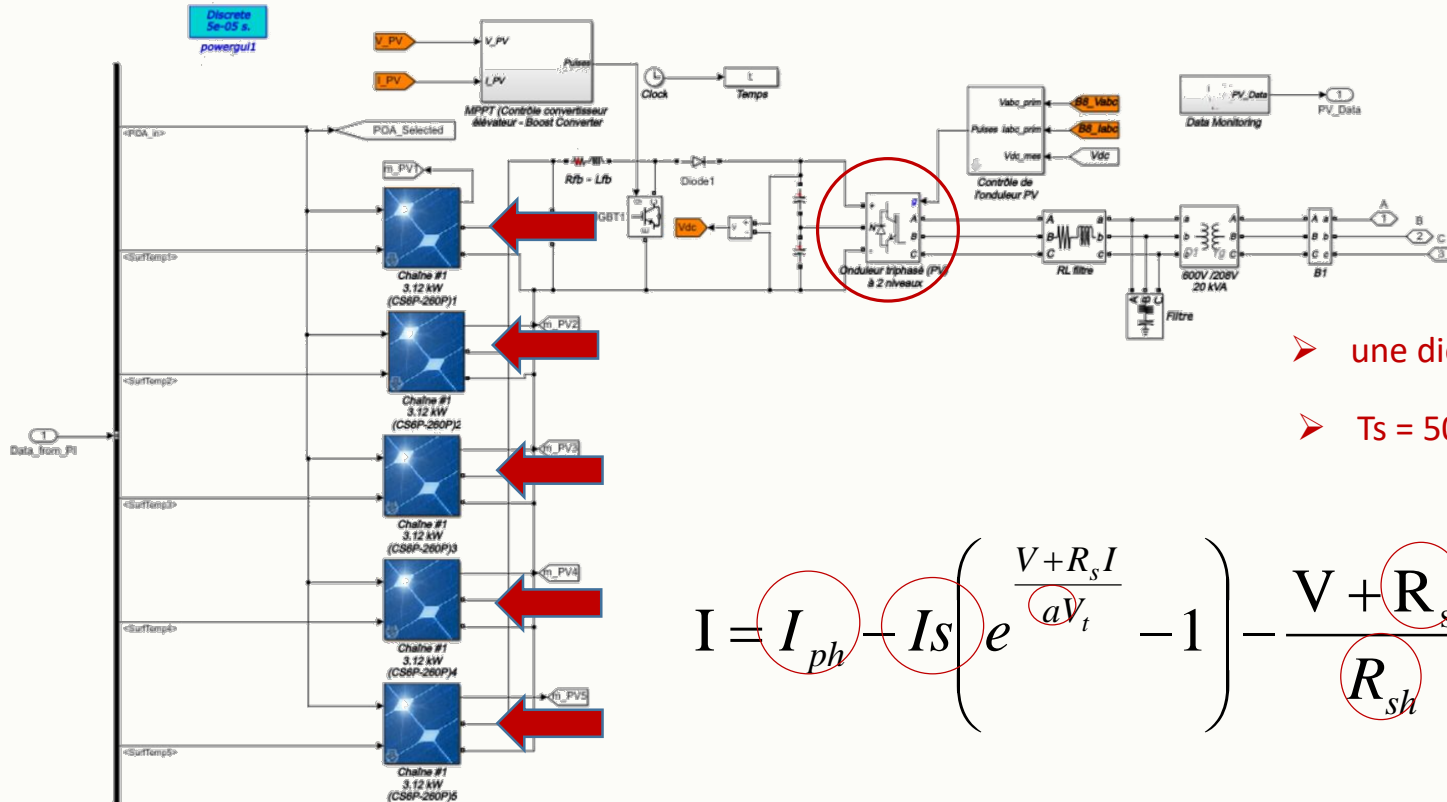

$$I = I_{ph} - I_s \left(e^{\frac{V + R_s I}{a V_t}} - 1 \right) - \frac{V + R_s I}{R_{sh}}$$



Résultats préliminaires

Jumeau numérique système solaire PV

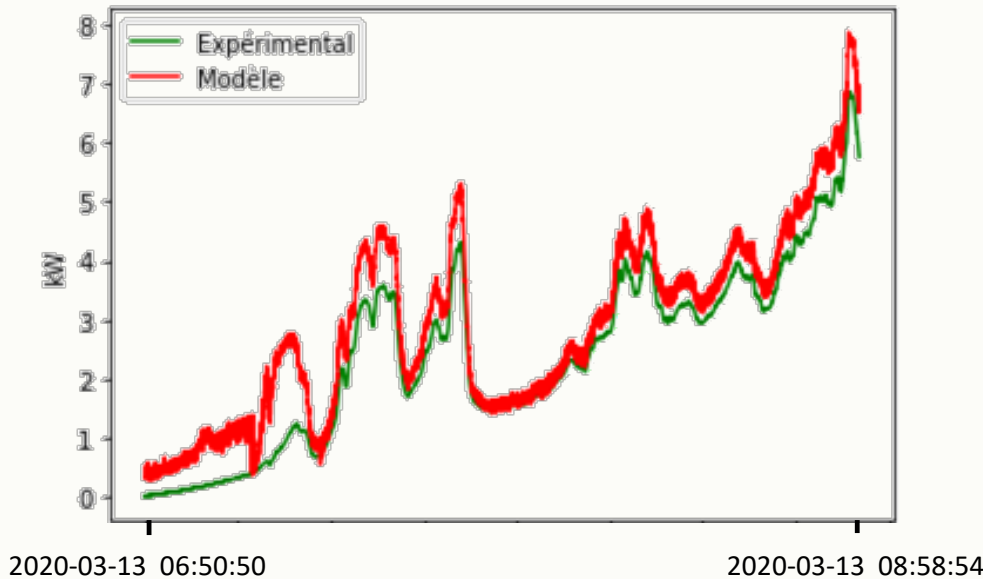

$$RSS = \sum_{i=1}^n (y_i - f(x_{1i}, \dots, x_{li}; a_1, \dots, a_m))^2$$

$$RMSR = \sqrt{\chi_{red}^2} = \sqrt{\frac{1}{n-p} \sum_{i=1}^n (y_i - \hat{y}_i)^2}$$



Résultats préliminaires

Jumeau numérique - Modèles numériques en développement

Générateur à courant alternatif

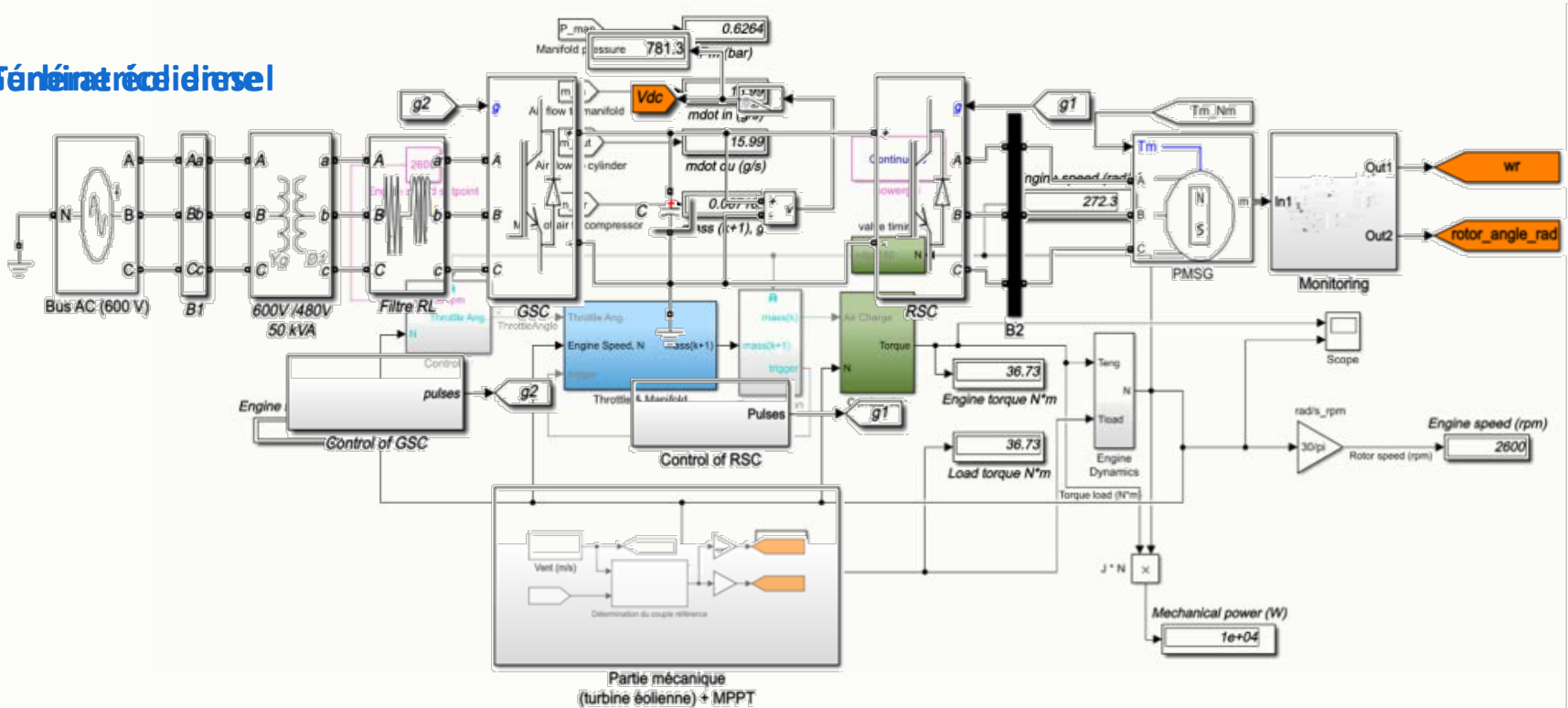





Critères pour qu'un JN soit complet

- **Lien de communication**
- **Ajustement des paramètres du modèle**
- **Stockage dans un système infonuagique**
- **Temps réel / visualisation des données**
- **Calcul d'erreur**

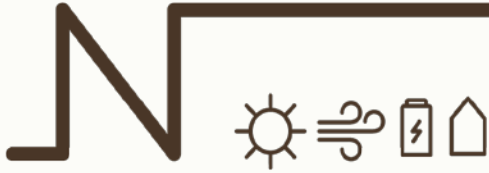

Conclusion et perspectives

- Développement novateur
- Trois avantages importants :
 - augmentation du taux de pénétration
 - développement de contrôleurs de microréseaux
 - amélioration des performances (maintenance prédictive)
- Résultats préliminaires prometteurs
- Développements à venir



Soumettez votre projet

ÉTAPES À SUIVRE

1

Visiter le
[nergica.com/
financement](http://nergica.com/financement)

2

Remplir le
formulaire

Vérification de
votre admissibilité

3

Signer l'entente
de service avec
Nergica

4

Réaliser votre
projet

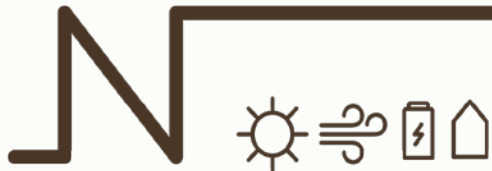

Communiquez avec nous

Cédric Arbez, directeur recherche et innovation

carbez@nergica.com

418 368-6162, poste 237



<https://www.opal-rt.com/event/rt20/>

NERGICA



70, rue Bolduc, Gaspé, QC G4X 1G2
nergica.com

T +1 418 368-6162 | info@nergica.com

Nos principaux partenaires financiers



Développement
économique Canada
pour les régions du Québec

Canada Economic
Development
for Quebec Regions

Québec 

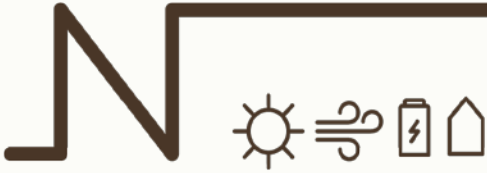

Bibliographie

- [1] E. Negri, L. Fumagalli, and M. Macchi, “A Review of the Roles of Digital Twin in CPS-based Production Systems,” *Procedia Manuf.*, vol. 11, no. June, pp. 939–948, 2017.
- [2] A. Fuller, Z. Fan, and C. Day, “**Digital Twin: Enabling Technology, Challenges and Open Research**,” 2019.
- [3] F. Tao and Q. Qi, “**Make more digital twins**,” *Nature*, vol. 573, no. 7775, pp. 490–491, 2019.
- [4] B. Marr, “**7 Amazing Examples of Digital Twin Technology In Practice**.” [Online]. Available: <https://www.forbes.com/sites/bernardmarr/2019/04/23/7-amazing-examples-of-digital-twin-technology-in-practice/#5ae5605a6443>. [Accessed: 02-Apr-2020].
- [5] J. Garfinkel, “**Gartner Identifies the Top 10 Strategic Technology Trends for 2019**,” 2018. [Online]. Available: <https://www.gartner.com/en/newsroom/press-releases/2018-10-15-gartner-identifies-the-top-10-strategic-technology-trends-for-2019>. [Accessed: 27-Mar-2020].
- [6] C. Pettey, “**Prepare for the Impact of Digital Twins**,” 2017. [Online]. Available: <https://www.gartner.com/smarterwithgartner/prepare-for-the-impact-of-digital-twins/>. [Accessed: 27-Mar-2020].
- [7] B. Marr, “**One Of The World’s Most Watched TV Shows Will Be Hosted By Artificial Intelligences**,” *Forbes.Com*, 2019. [Online]. Available: <https://www.forbes.com/sites/bernardmarr/2019/01/29/the-worlds-most-watched-tv-show-will-be-hosted-by-artificial-intelligences/#79c315b768de>. [Accessed: 02-Apr-2020].
- [8] P. van Manen, “**Digital twins in F1 and the built environment**,” *Institute of civil engineers*, 2019. [Online]. Available: <https://www.ice.org.uk/news-and-insight/the-civil-engineer/july-2019/digital-twins-in-f1-built-environment>. [Accessed: 02-Apr-2020].

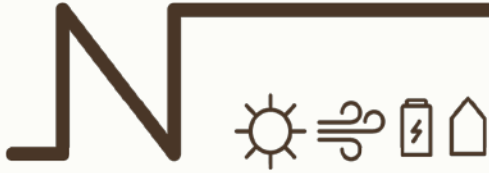

- [9] Siemens, “**Jumeau numérique.**” [Online]. Available: <https://www.plm.automation.siemens.com/global/fr/our-story/glossary/digital-twin/24465>. [Accessed: 02-Apr-2020].
- [10] Siemens, “**From vehicle design to multi-physical simulations.**” [Online]. Available: <https://new.siemens.com/global/en/markets/automotive-manufacturing/digital-twin-product.html>. [Accessed: 02-Apr-2020].
- [11] P. Aivaliotis, K. Georgoulas, and G. Chryssolouris, “**The use of Digital Twin for predictive maintenance in manufacturing,**” *Int. J. Comput. Integr. Manuf.*, vol. 32, no. 11, pp. 1067–1080, 2019.
- [12] A. Eshkenazi, “**Real Benefits from Digital Twins,**” 2018. [Online]. Available: <http://www.apics.org/sites/apics-blog/thinking-supply-chain-topic-search-result/thinking-supply-chain/2018/09/21/real-benefits-from-digital-twins>. [Accessed: 02-Apr-2020].
- [13] K. Bruynseels, F. S. de Sio, and J. van den Hoven, “**Digital Twins in health care: Ethical implications of an emerging engineering paradigm,**” *Front. Genet.*, vol. 9, no. FEB, pp. 1–11, 2018.
- [14] P. Liceras, “**Singapore experiments with its digital twin to improve city life.**” [Online]. Available: <https://www.smartcitylab.com/blog/digital-transformation/singapore-experiments-with-its-digital-twin-to-improve-city-life/>. [Accessed: 04-Feb-2020].
- [15] GE Renewable Energy, “**BUILDING A DIGITAL TWIN, BOLSTERING THE POWER OF A WIND TURBINE.**” [Online]. Available: <https://www.ge.com/renewableenergy/stories/improving-wind-power-with-digital-twin-turbines>. [Accessed: 02-Apr-2020].
- [16] GE Renewable Energy, “**A BREAKDOWN OF THE DIGITAL WIND FARM.**” [Online]. Available: <https://www.ge.com/renewableenergy/stories/meet-the-digital-wind-farm>. [Accessed: 02-Apr-2020].
- [17] P. Jain, J. Poon, J. P. Singh, C. Spanos, S. R. Sanders, and S. K. Panda, “**A digital twin approach for fault diagnosis in distributed photovoltaic systems,**” *IEEE Trans. Power Electron.*, vol. 35, no. 1, pp. 940–956, 2020.
- [18] Reuniwatt, “**Solar Asset Management avec SunSatTM Digital Twin.**” [Online]. Available: <https://reuniwatt.com/fr/2019/10/21/manager-solar-asset-avec-sunsat-digital-twin/>. [Accessed: 02-Apr-2020].
- [19] Q. Qi et al., “**Enabling technologies and tools for digital twin,**” *J. Manuf. Syst.*, no. October, pp. 0–1, 2019.



- [20] M. R. Enders and N. Hoßbach, “Dimensions of digital twin applications - A literature review,” 25th Am. Conf. Inf. Syst. AMCIS 2019, no. 1, pp. 1–10, 2019.
- [21] M. Shafto et al., “Modeling, Simulation, Information Technology & Processing Roadmap,” Natl. Aeronaut. Sp. Adm., pp. 1–38, 2012.
- [22] M. Grieves, “Digital Twin : Manufacturing Excellence through Virtual Factory Replication” White Pap., no. March, 2014.
- [23] Q. Qi and F. Tao, “Digital Twin and Big Data Towards Smart Manufacturing and Industry 4.0: 360 Degree Comparison,” IEEE Access, vol. 6, pp. 3585–3593, 2018.